

## EVMS Lite v1.0

### Introduction

Thank you for purchasing ZEVA's Electric Vehicle Management System. The EVMS was developed to address the need for safer, more reliable and better integrated EV conversions. The Lite module is a simplified version of our EVMS Core, for those who only need basic BMS functionality. The Lite communicates with battery management modules over CAN bus and manages your vehicle's drive and charge circuits according to battery status, automatically shutting down the vehicle if any cells exceed safe voltage range.

It also features auxiliary contactor control (for managing any mid-pack contactors), remote LED for viewing status from the cabin and a buzzer output for audible warnings of any errors. The EVMS Lite can optionally be used with an EVMS Monitor module for viewing current vehicle status as well as full BMS information such as individual cell voltages and pack statistics. The Monitor may also be used for reprogramming BMS parameters over the CAN bus.

This manual describes the installation and operation of the EVMS Lite, with some additional content describing interaction with the EVMS Monitor.

### Safety Warning

Electric vehicles are high powered devices which involve potentially lethal voltages and currents. Proper precautions and electrical safety procedures should always be observed, voltages above 110VDC should be considered dangerous, and vehicles should never be worked on while power contactor(s) are engaged. Please read this manual carefully to ensure correct installation and operation. If you are unsure of anything, please contact us before proceeding.

We have endeavoured to make a safe and reliable product which performs as described, however since ZEVA has no control over the integration of its products into a vehicle, we can assume no responsibility for the final safety or functionality of the completed vehicle.

It is up to the end user to determine the suitability of the products for the purpose employed, and the end user assumes all risks associated. Products should only be installed by suitably qualified and experienced persons, and should always be used in a safe and lawful manner.

### Specifications

- Power supply: 13.5V nominal (8-20V maximum)
- Current consumption: 5mA idle, 25mA active
- Contactor outputs rated at up to 5A
- Dual CAN bus ports (5-pin Molex KK)
- Dimensions: 82x56x10mm
- Weight: 20g

### EVMS Lite Installation

The EVMS Lite should be mounted securely in the vehicle using the four 3mm holes on the board, in a location protected from the weather. The Lite has nine mini quick connect (spade) terminals across one edge for its main connections, plus dual CAN ports on opposite sides. Wire gauge for most I/O connections should be around 18-20AWG to ensure reasonable mechanical strength and current rating.

The following page shows a typical wiring diagram for an EVMS Lite in a vehicle (plus associated BMS modules and EVMS Monitor).

## Wiring Diagram

The diagram below shows typical wiring for a complete EVMS installation. Note that the diagram does not show a main fuse (5A recommended) and inertia switch (crash sensor), which should both be installed between the 12V battery and the EVMS Lite's 12V supply. You will also usually need to separately use the key signal to switch a relay for powering auxiliary devices such as brake vacuum pump, power steering pump, water cooling pump, cabin heater, etc. Make sure all wiring has appropriate current and insulation ratings, and that fuses have appropriate DC voltage and current ratings.

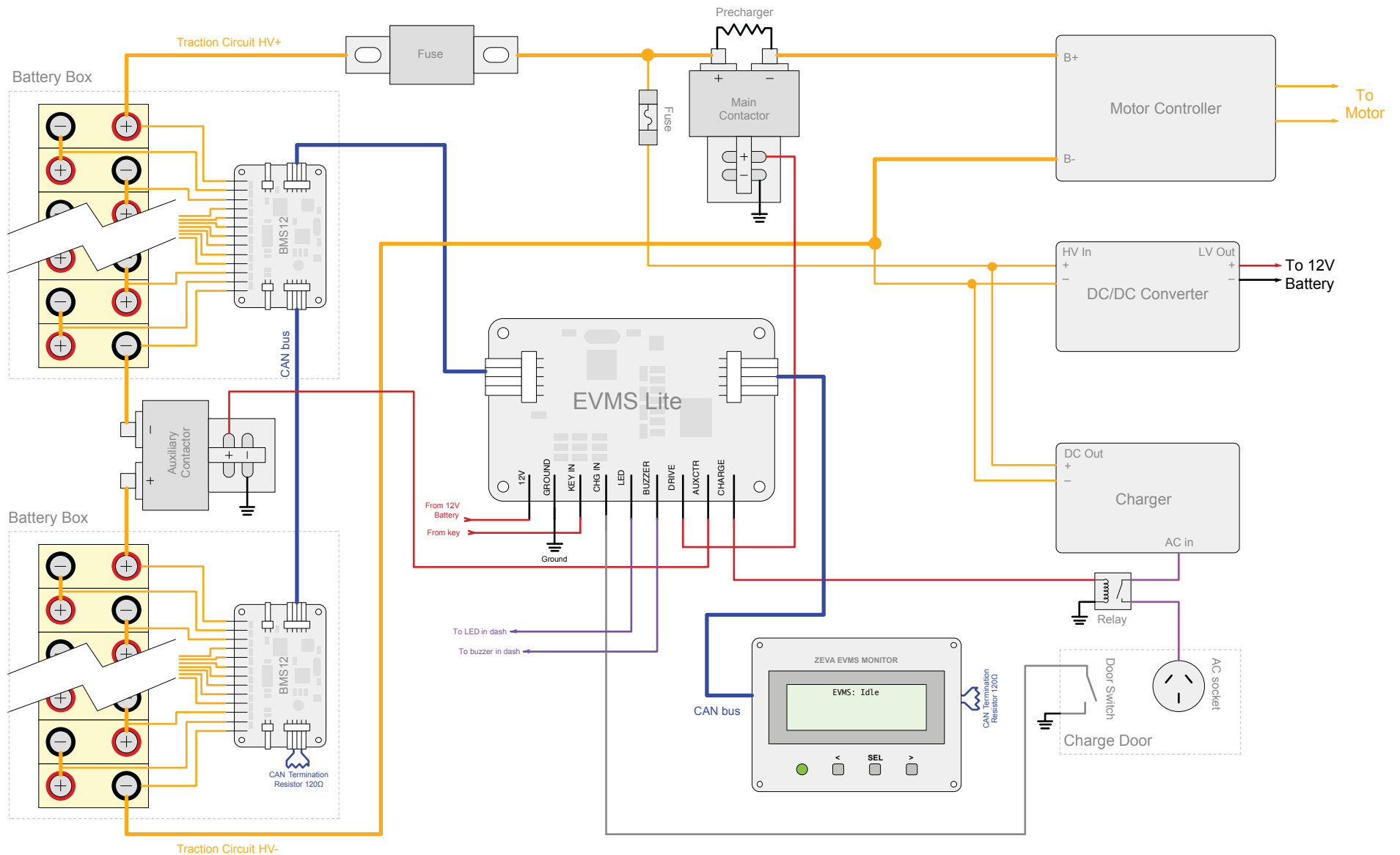

## Description of EVMS Lite connections

Terminal name	I/O	Description
12V	Input	To 12V battery positive (permanent supply, not key switched). Approx 9-18V maximum range.
Ground	Input	To vehicle chassis, or 12V battery negative.
Key in	Input	To key signal, should be +12V when key is turned on
Charge In	Input	Connect to your charge detection switch, such as a fuel door switch or 240V detect relay/circuit. Should pull to ground when the switch is on (so attach other side of switch to chassis, near the switch is fine).
LED	Output	Allows for wiring of a remote LED for viewing status in cabin. 5mA limited. Connect this pin to LED anode, and cathode to ground/chassis.
Buzzer	Output	Connect a 12V piezo buzzer to this output pin for an audible warning when errors are detected.
Drive	Output	Supplies 12V to the main contactor, precharge system or motor controller while the key is on and the BMS reports no errors.
Aux Ctr	Output	Supplies 12V to any auxiliary contactors you may have such as pack break-up contactors, while either driving or charging.
Charge	Output	Supplies

## CAN Bus Wiring

The EVMS Lite also has two CAN bus ports (5-pin Molex C-Grid SL) on one side of the case. These are wired identically, and can be connected in either order in any location along the CAN bus. (The EVMS Monitor and BMS12 modules use the same 5-pin plugs and wiring.)

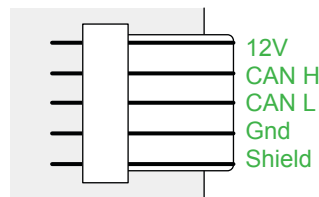

CAN pin assignments on 5-pin plugs

CAN buses work best when wired as a single daisy chain of devices, with 120ohm termination resistors at each end to prevent signal reflection. For this reason all ZEVA CAN-enabled devices have dual CAN ports for easy daisy-chaining. The order of devices is unimportant - usually the shortest path between devices is best.

For the sake of noise immunity, CAN buses typically use twisted pair cable. Since electric

vehicles can involve high electromagnetic interference (EMI) from the traction circuit, we recommend using shielded twisted pair (STP) wire for maximum noise immunity. Very short connections are usually OK with untwisted and/or unshielded cable.

## EVMS Monitor

The EVMS Monitor is used to remotely interact with other devices on the CAN bus, both for viewing operating data and to edit settings. The Monitor has various different pages of information as described below.

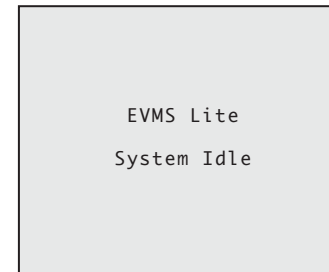

The default display when the vehicle is idle (neither driving nor charging).

In order to minimise quiescent power consumption while the vehicle is not in use, the EVMS Lite will power down the CAN bus after 1 minute in idle state. You can use this time window to enter Options and Settings modes.

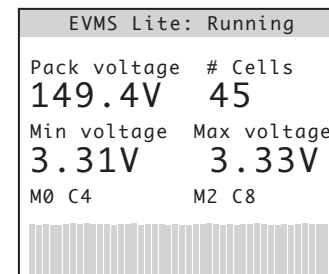

The standard display when the vehicle is running or charging, showing the pack voltage (total of monitored cells), total number of cells, and the voltage and location of both the lowest and highest cells.

Along the bottom is a bar graph showing all cells being monitored. Green bars indicate cells within range. Bars will change to blue for undervoltage cells, orange for cells being balanced, and red for overvoltage cells.

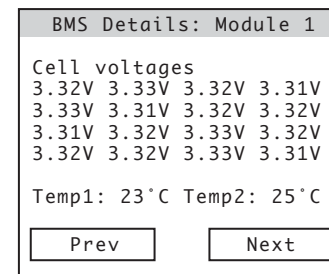

Detailed information for a single BMS module, showing voltage of each cell (to 2 decimal places) and two temperatures if available. Orange bars beneath the voltages indicate if cell shunts are currently on.

Touch within the Prev and Next buttons to change which BMS module is being viewed, or anywhere else in the display to change Monitor pages.

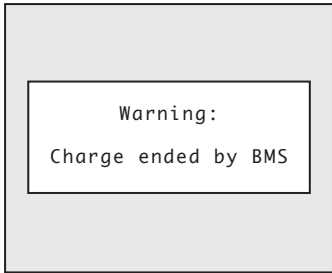

If the EVMS detects an error, this warning page will be displayed. In most cases, the error can be acknowledged/reset by pressing Select. For a full list of errors you might see, refer to section *Error Detection*.

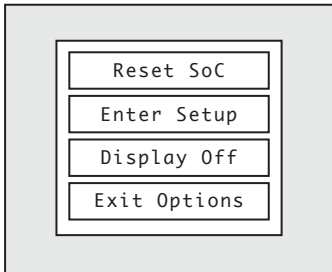

You can bring up this options menu by holding your finger down for 1 second. From here you can enter the Setup mode, or switch the display off. (Note that Reset SoC only works with EVMS Core.)

When the display is off, touch and hold anywhere for 1 second to turn it back on. Display will automatically wake if there is a new warning to display.

Setup mode can only be entered from Idle state, i.e when the vehicle is not charging or being driven.

### Configuring Settings

The EVMS Monitor can be used to configure settings for all devices on the CAN bus.

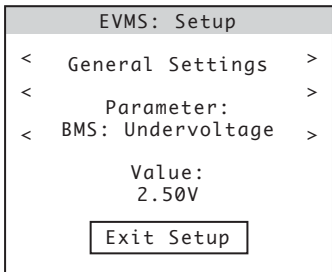

The Setup mode has three rows. The top row toggles between the General Settings and the Pack Configuration sections. Tap the arrows either side to navigate between these. In the General Settings page, the second row selects the parameter to be modified, and the third row modifies the parameter itself. The Exit Setup button will distribute new settings to all devices on the network then return to normal operation.

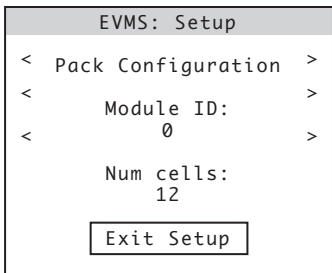

This is the page for configuring your battery pack, so the BMS knows how many cells to monitor.

Tap the arrows either side of the Module ID row to select the module in question, and the arrows either side of Num cells is used to modify how many cells that BMS module should expect.

### List of settings - EVMS Lite

The following table describes the parameters available in the General Settings page.

Name	Range	Description
BMS: Min voltage	0 - 5.00V	Adjusts the low voltage warning threshold for each cell in your traction pack.
BMS: Max voltage	0 - 5.00V	Adjusts the high voltage warning threshold for each cell in your traction pack.
BMS: Shunt voltage	3.00 - 5.00V	Adjusts the voltage at which shunt balancers turn on for each cell in the traction pack.
BMS: Low temp warn	0-100°C	The EVMS can provide a warning if any BMS modules report a temperature below or above these respective thresholds.
BMS: Overtemp warn	0-100°C	
Stationary Mode	YES/NO	Switches the EVMS into Stationary Mode, for battery backup and off-grid power type applications. Please refer to "Stationary Applications" Section for more information.
Display brightness	0-100%	Adjusts the brightness of the LCD display's backlight.
Display fade delay	0-20sec	Changes the length of time the display will remain lit after a button press, change of state or warning notification.
Buzzer On	YES/NO	Selects whether the Monitor should sound the buzzer for alerts. (Safest to leave this on.)
Use Fahrenheit	YES/NO	Changes display of temperature units to Fahrenheit instead of Celcius.

### Error Detection

The EVMS monitors a wide range of operating parameters for your electric vehicle and can notify you if any exceed their safe range or any faults are detected. In most cases, errors can be acknowledged/reset by pressing the Select button. Critical errors are responded to automatically (such as by shutting down the traction circuit due to a critically low cell), while others are at the driver's discretion to respond to (such as over-temperature warnings). The following table describes the errors you may encounter.

Error	Description
-------	-------------

Corrupt Settings	Occurs if memory corruption has been detected in the EVMS Lite's saved settings (they will automatically be reset to defaults). Contact us if you see this one.
BMS - low cell	A BMS module has reported a cell voltage below the minimum threshold.
Shutdown by BMS	A low cell condition has been present for more than 10 seconds, so the EVMS has shut down the traction circuit to protect the batteries.
BMS - high cell	A BMS module has reported a cell voltage above the minimum threshold.
Charge ended by BMS	A high cell condition has been present for more than 1 second, so the EVMS has shut down the charger to protect the batteries.
BMS - overtemp	A BMS module has reported a temperature above the programmed threshold.
BMS - comms error	If the EVMS Lite hasn't received data from a BMS module for a while (about 1 second), this error will appear and the traction circuit will be shut down for safety.

### Stationary Applications

The EVMS configuration includes a setting for Stationary Mode, intended for use in battery backup and off-grid power applications. In this mode, the Key input enables both Main Contactor and Charge Enable outputs concurrently. An undervoltage cell will disable the Main Contactor output (to remove any loads on the battery) and an overvoltage cell will disable the Charge Enable output (to disable any charging sources). In both cases the outputs are re-enabled once the voltage has recovered by 0.4V (i.e there is  $\pm 0.2V$  hysteresis around the configured thresholds).

In Stationary Mode, the Charge Sense input is no longer used, typically the Aux Ctr output will not be used, and precharging is not supported.

For LiFePO4, we recommend an undervoltage threshold of 2.8V (which results in 2.6V cutout and 3.0V re-enabling for any loads on the battery), and an overvoltage threshold of 3.6V (for 3.8V charger cutout and 3.4V re-enabling). These thresholds give about 1% hysteresis on the battery state of charge to avoid rapid cycling of the charger or outputs.

### Tech notes

- **CAN bus power:** CAN busses use a significant amount of power when operating. In order to minimise quiescent power consumption (and avoid flattening your vehicle's 12V battery), the EVMS Lite powers down the CAN bus after 1 minute if the vehicle is neither driving or charging. As such, the BMS will no longer be monitoring your cells so it is of paramount importance that there are **no loads on the traction battery when the vehicle is idle**, or batteries could be damaged from over-discharge!

If the outputs are disabled due to a BMS error (such as over-voltage or under-voltage cell), the CAN bus will remain active for 1 hour. This is to allow a window for the BMS modules to continue pack balancing even after the charger has been switched off, before the CAN bus is powered down to avoid flattening the auxiliary battery.

Once the CAN bus has powered down, you will be unable to enter Setup mode with a Monitor device. To remedy this, simply turn the key on and off, or turn the EVMS Lite off and on again, then enter Setup as normal within 1 minute.

- **Precharging your motor controller:** Motor controllers have a large input capacitor bank which must be precharged / soft started, to avoid a large inrush current when your contactor closes which can damage components. The EVMS Lite includes no controller precharge system, so you will need to arrange a precharge device for your motor controller if it does not have one built in. (Check out our Smart Precharger on the ZEVA website for more info.)

### Tech support and warranty information

All ZEVA products are covered by a 12 month warranty against manufacturing faults or failures under normal operating conditions. The warranty does not cover misuse of the product, including but not limited to: excessive voltage or reversed polarity on terminals, short circuits on outputs, opening of housings and/or modification of internal electronics, severe impact damage (e.g due to vehicle crashes), submersion in water.

We have taken great care to design a safe and reliable product, but faults can happen. If you believe your product has a fault, please contact us via our website to discuss. If it is determined that a hardware fault is the likely cause, we will provide an RMA number and return address to proceed with repairs.

If you have any questions not covered by this manual, please contact us via our website:

<http://www.zeva.com.au>